

INSTALLATION & OWNER'S MANUAL

ULTRA COMPACT NICHE LIGHT

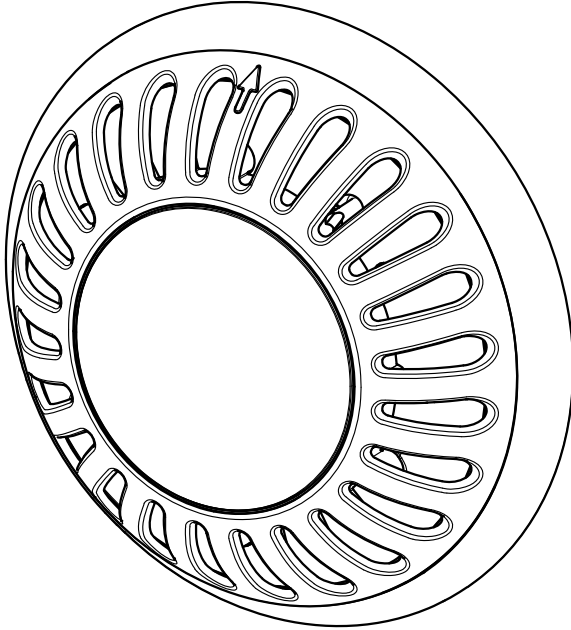

EMRX

FOR RETRO-FITTING EXISTING POOLS

STORE THIS MANUAL IN A SAFE
PLACE FOR FUTURE REFERENCE



Australian designed & made

CONTENTS

READ THIS FIRST	3
TOOLS REQUIRED	4
IMPORTANT NOTE	4
PRODUCT SUPPORT AND INFORMATION	4
INCLUDED PARTS	5
FINISHED INSTALLATION (DIAGRAM)	6
ASSEMBLY (STEPS 1-19)	7 - 16
INSTALL EMRX TO NICHE	17
EM-1 INSTALLATION (DIRECT)	20
WALL MOUNTING GUIDE (DIRECT)	23
EM-1 INSTALLATION (REMOTE)	24
WALL MOUNTING GUIDE (REMOTE)	27
TROUBLESHOOTING	28

READ THIS FIRST!

This booklet contains important information about the correct installation and handling of EM-series lights. **Please read this booklet carefully** before commencing installation to familiarise yourself with the included parts, accessories and correct installation procedures.

BEFORE YOU START:

- Ensure that the lighting system is installed by a suitably qualified persons (e.g. registered pool builder and/or qualified electrician), in accordance with AS/NZS 3000:2007 standards.
- For safe and proper installation, ensure that only those parts supplied with the system are used.
- Check that there is enough cable behind the existing light to allow for servicing above water, preferably *at ground-level pool-side*.
- Ensure the pool light end of cable is circular and free of damage or imperfections i.e. cuts, cracks or deformation. *If possible, trim cable back until a fresh end of cable is available.*
- Confirm existing transformer is a magnetic type, **12V AC ONLY** and in good working order (If in doubt contact Spa Electrics.)
- If multiple EMRX lights are installed, ensure the red "CLICK FIT" tab is located in a consistent orientation to ensure uniform visual appearance of the LED colours. (See Page 18 for further information.)
- The EM series light can be mounted at any angle provided the installation conforms to the above.

CLEANING

- Only use warm water and a soft brush or cloth to clean EM-series lights. DO NOT use detergents or spirits as this can damage the light and void your warranty.

USE

- Do not operate light unless completely submerged in water.
- Operating the light for at least 15 minutes every week is advised (all year round).
- EM-series lights are designed for continuous (24/7) operation.
- EM-series lights are suited for both domestic and commercial installations

WARNING

- The EM series light must only be powered by a **12V AC** magnetic-type transformer.
- DO NOT use electronic or switch-mode transformers with EM-series lights. These transformers will damage the light and void your product warranty.
- **Pool chemicals & PH levels:** Due to the corrosive nature of unbalanced pool chemicals, Spa Electrics strongly recommend that your pool water is balanced prior to installing your pool lights or any plastic or stainless steel components, and tested weekly to maintain these levels. pH levels should be maintained between 7.2 – 7.6 at all times to ensure the longevity of these components.
 - > Failure to do so can result in chemical damage to the light housing and pool fittings, including stainless steel components.
 - > **Please note:** Lights or components found to have excessive chemical damage will not be covered under our manufacturer's warranty policy
- This light contains no user-serviceable parts; opening the light will void the product warranty.

TOOLS REQUIRED

MODEL: EMRX

- > Flat-blade screw-driver
- > Phillips head (No 2) screw-driver
- > Cable stripper
- > Pliers

IMPORTANT NOTE (1):

The use of power tools (such as 240V and cordless drills) during installation is **not** recommended as these devices can cause faults and damage to light components.

All EMRX installation steps should be carried out with manual tools only.

IMPORTANT NOTE (2):

Before commencing retro-fit installation of EMRX light to PAL Niche, you must ensure that all connected transformers are **12V AC magnetic-type only**.

If in doubt, contact Spa Electrics.

PRODUCT SUPPORT AND INFORMATION:

Phone: +61 3 9793 2299 (business hours)

Email: info@spaelectrics.com.au (SALES enquiries)

Email: tech@spaelectrics.com.au (TECHNICAL support enquiries)

Web: www.spaelectrics.com.au

INCLUDED PARTS

MODEL: EMRX

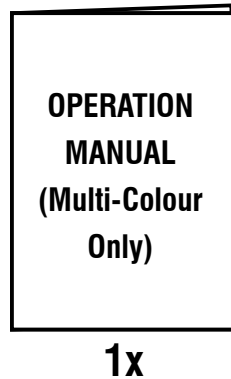
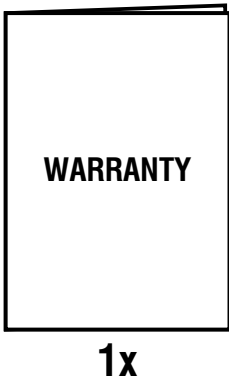
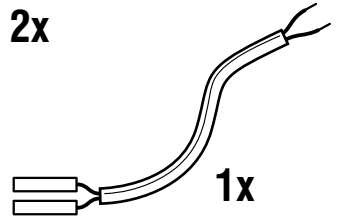
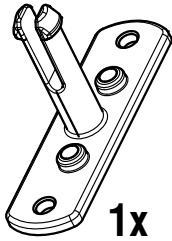
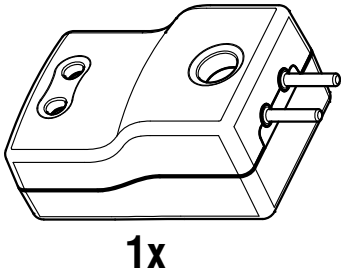
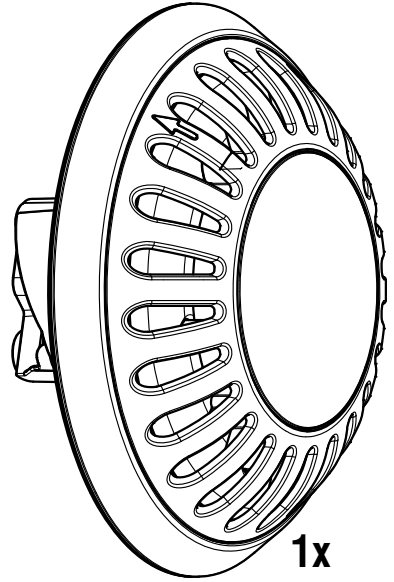
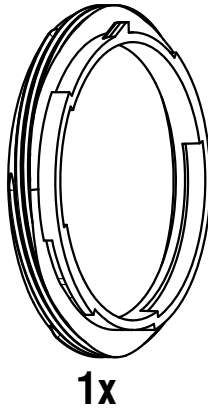
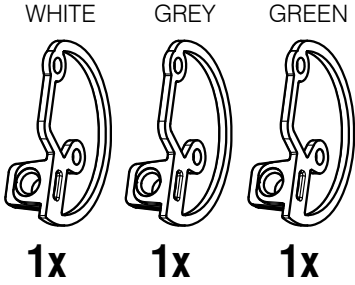

FINISHED INSTALLATION

MODEL: EMRX (RETRO-FIT EXISTING POOLS)

EXISTING
POOL WALL

EXISTING NICHE *

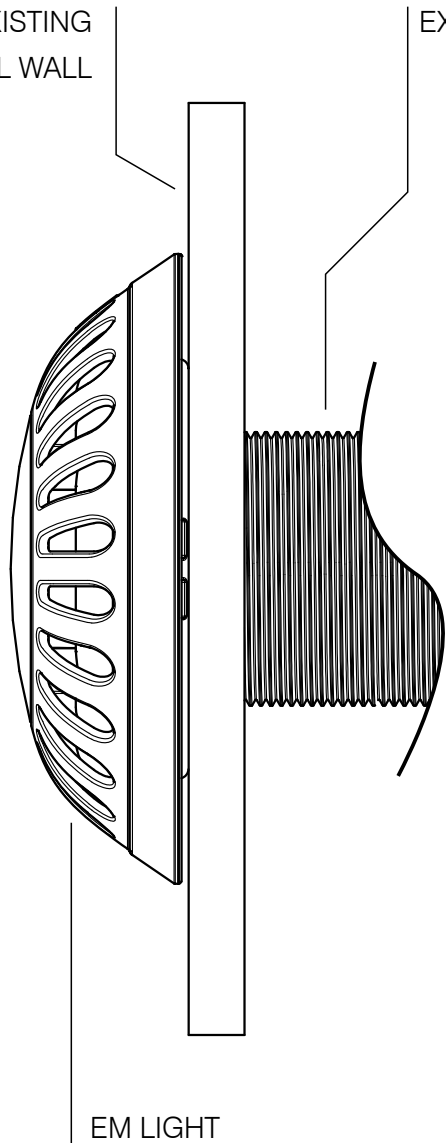

EM LIGHT

* FOR ILLUSTRATIVE PURPOSES ONLY.
ACTUAL NICHE DESIGN MAY VARY

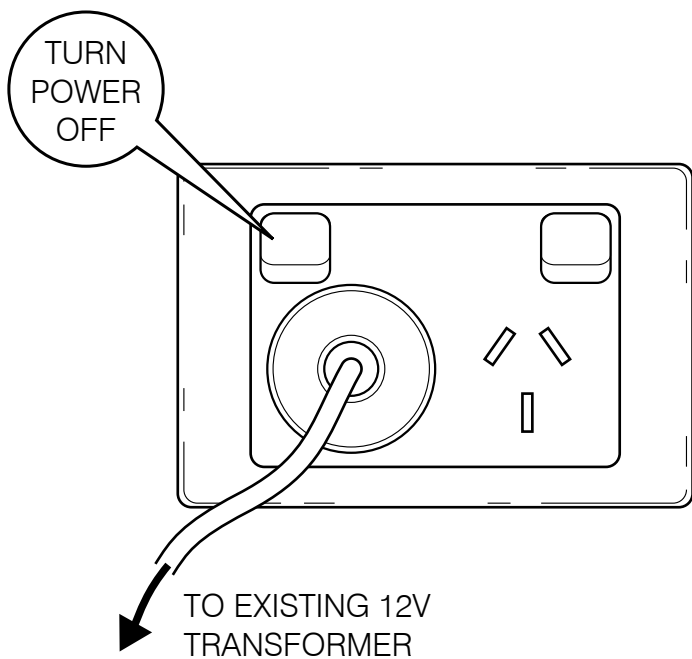
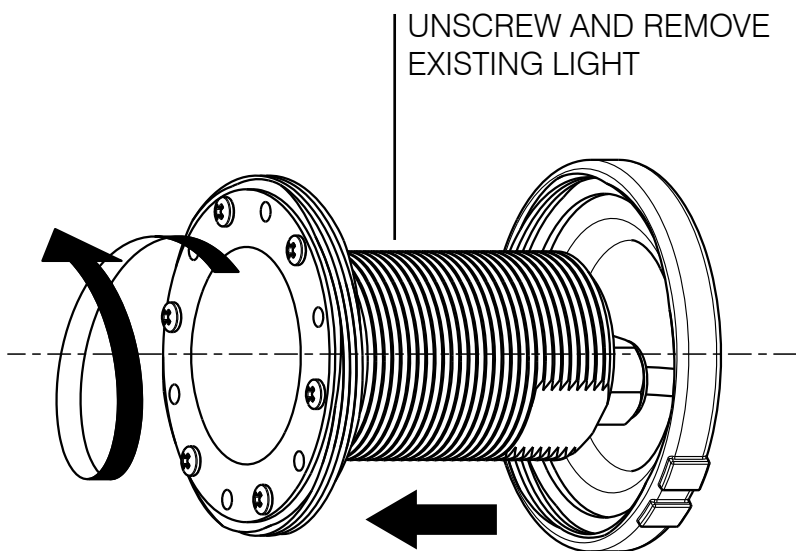
1**2**

3

CUT CABLE AT REAR
OF EXISTING LIGHT

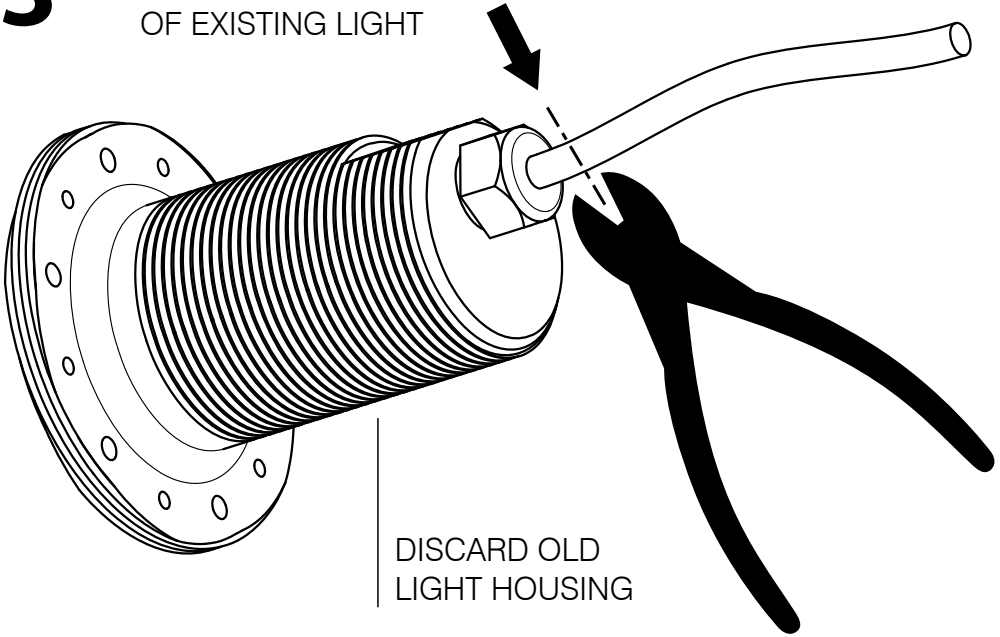

DISCARD OLD
LIGHT HOUSING

4

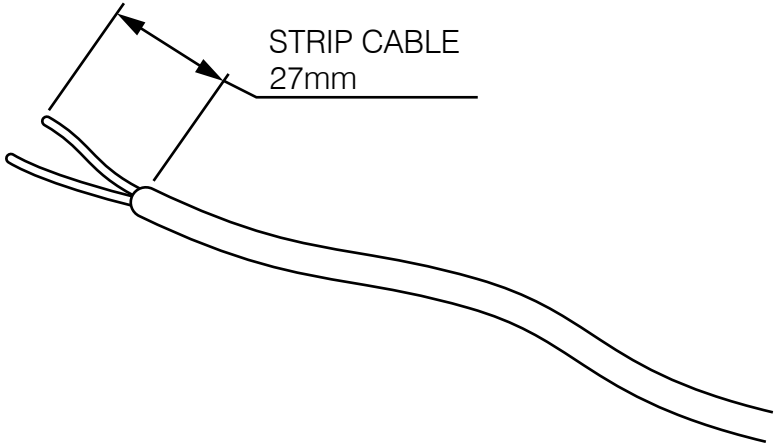

STRIP CABLE
27mm

5 STRIP WIRES

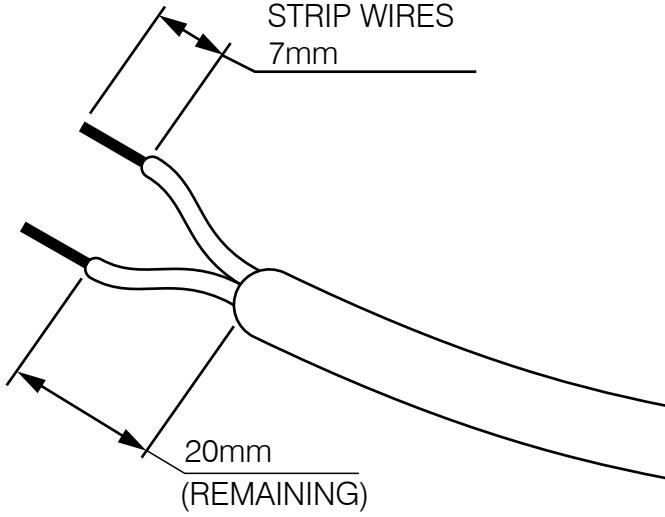

6

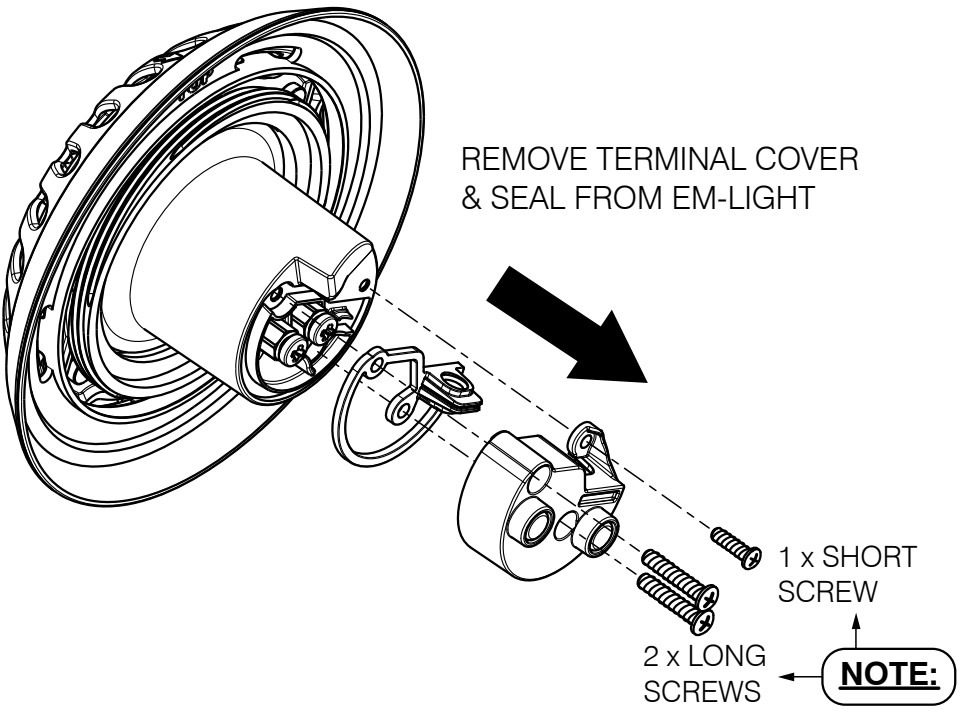

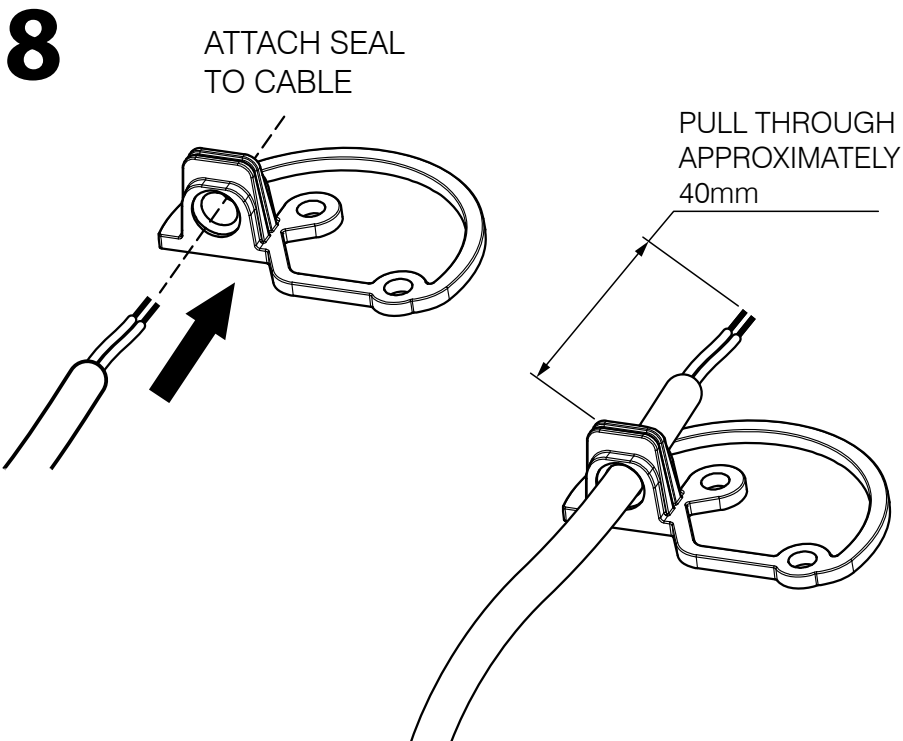
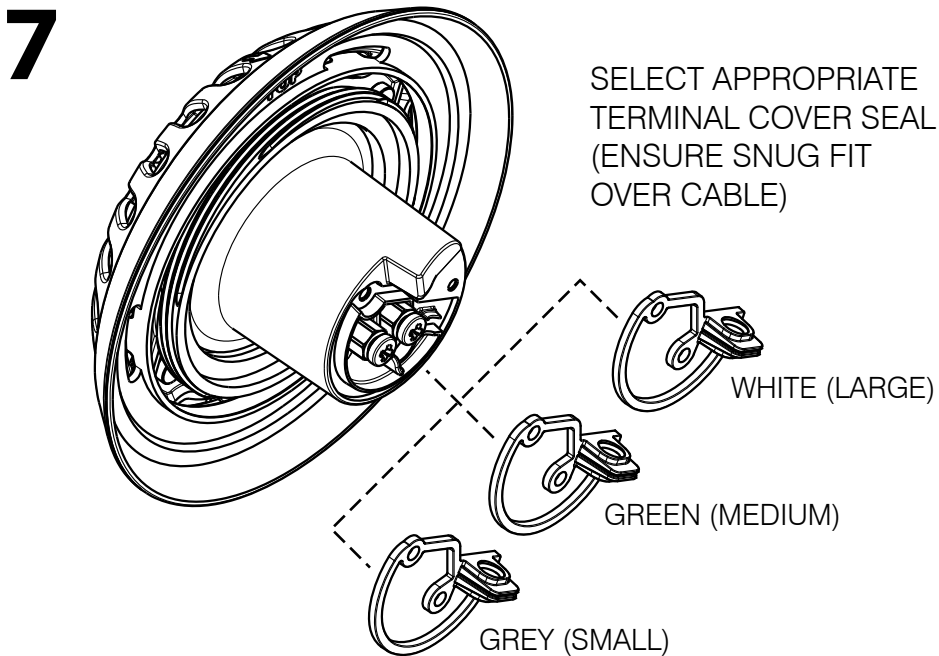

9 FOLD SEAL OVER CABLE

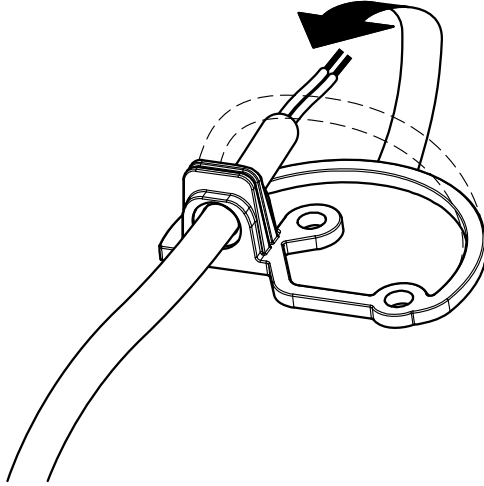

10



LOOSEN TERMINAL FASTENERS
(DO NOT REMOVE)

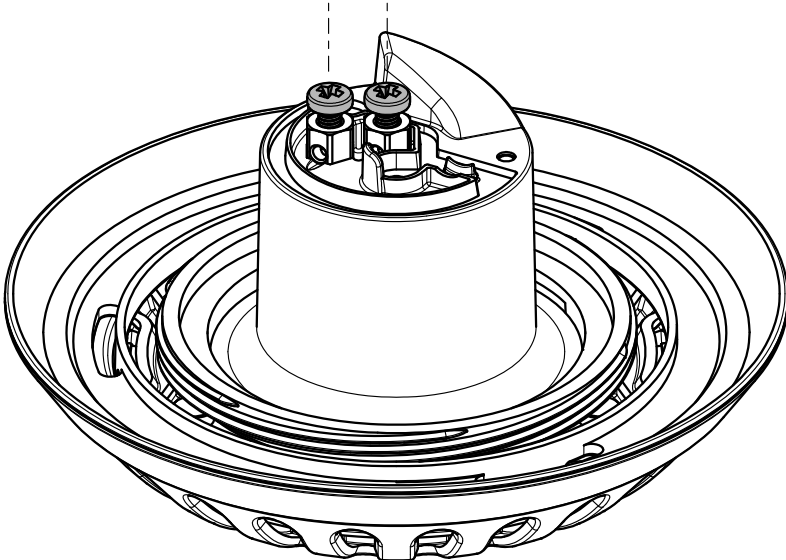

11

INSERT WIRES INTO TERMINALS

12

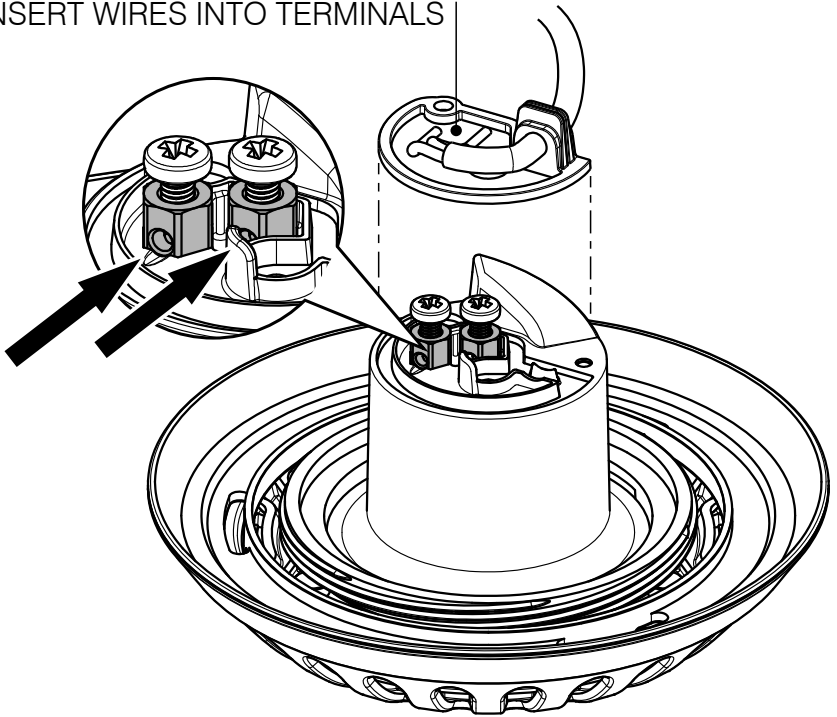

12

TIGHTEN
TERMINAL
SCREWS

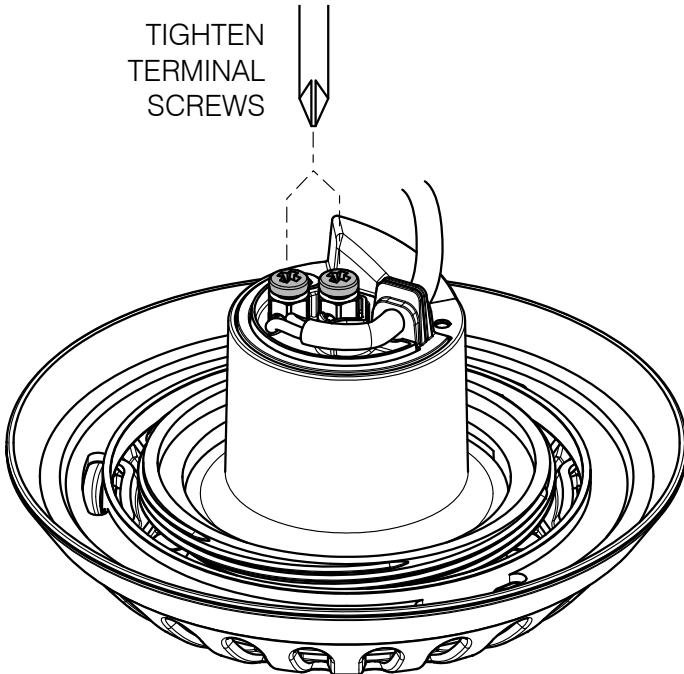

13

(RUN FINGER
AROUND SEAL
TO SEAT FULLY
WITHIN GROOVE)

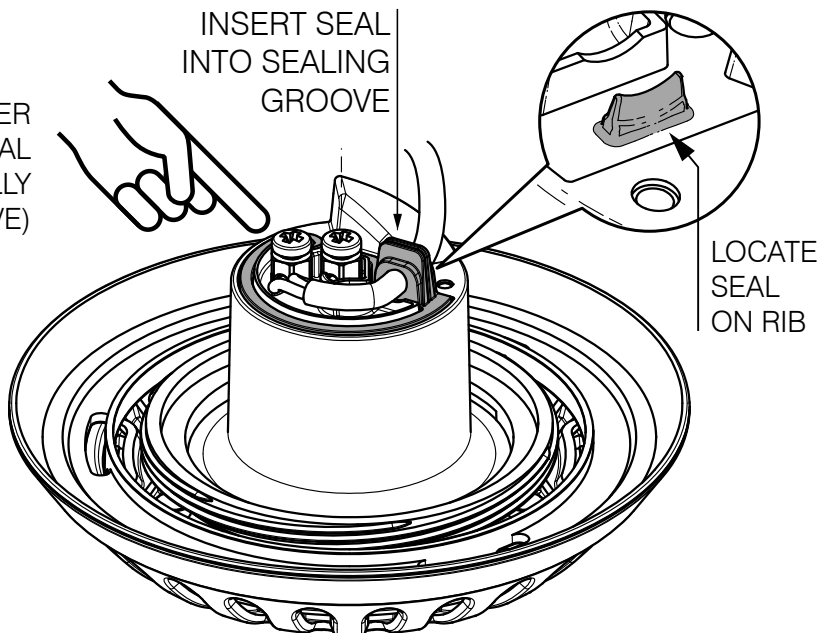

14

ENSURE SEALING
BEAD AND GROOVE
ARE ALIGNED AND
ACCURATELY COM-
PRESSED TOGETHER

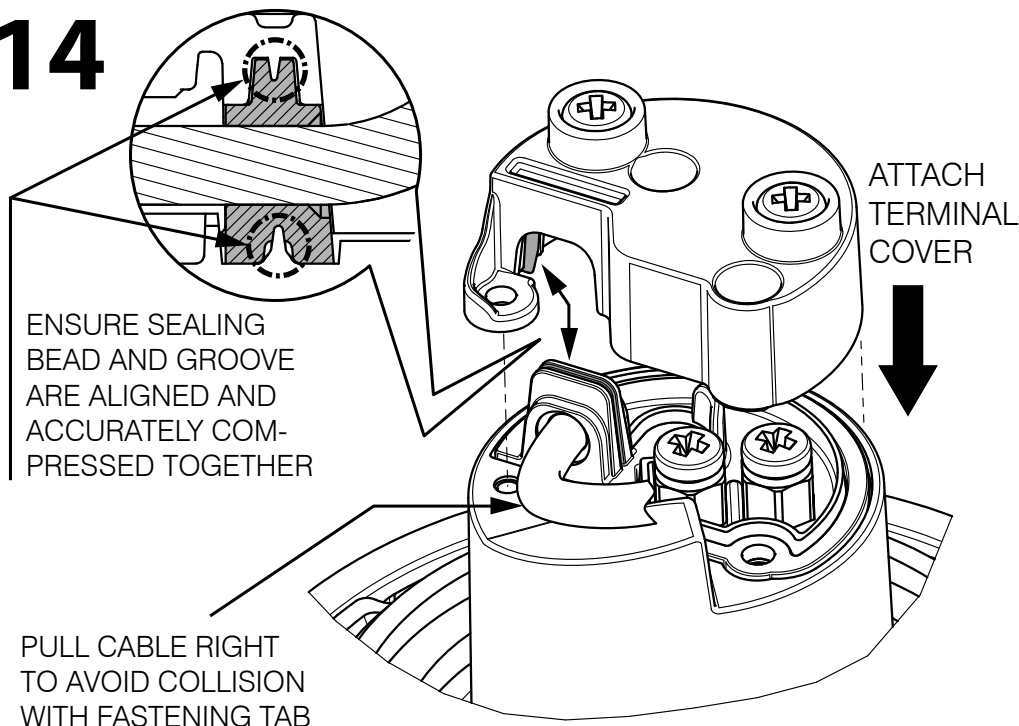

15

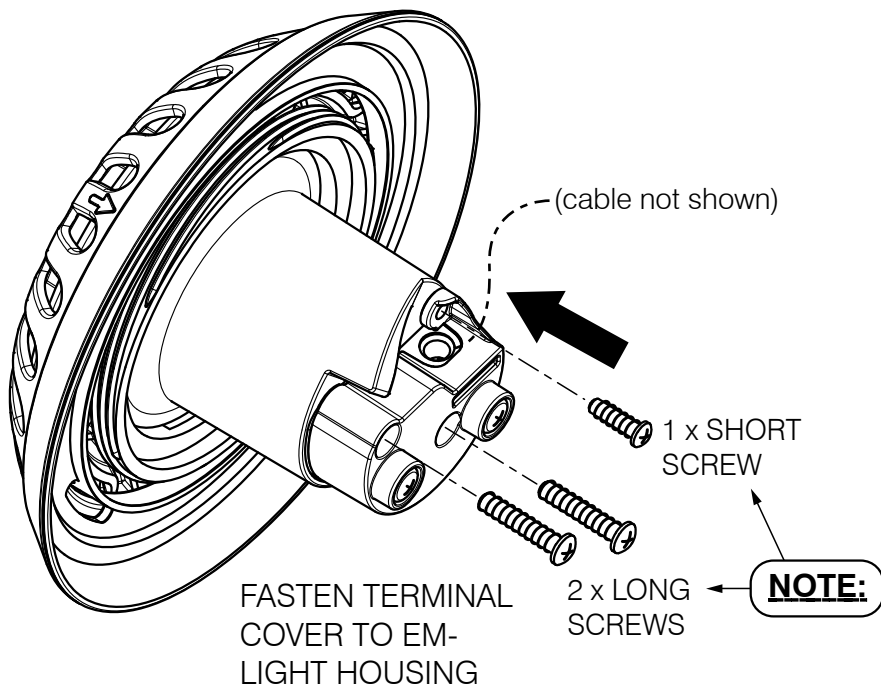

16

ENSURE O-RINGS STAY SEATED WITHIN TERMINAL COVER

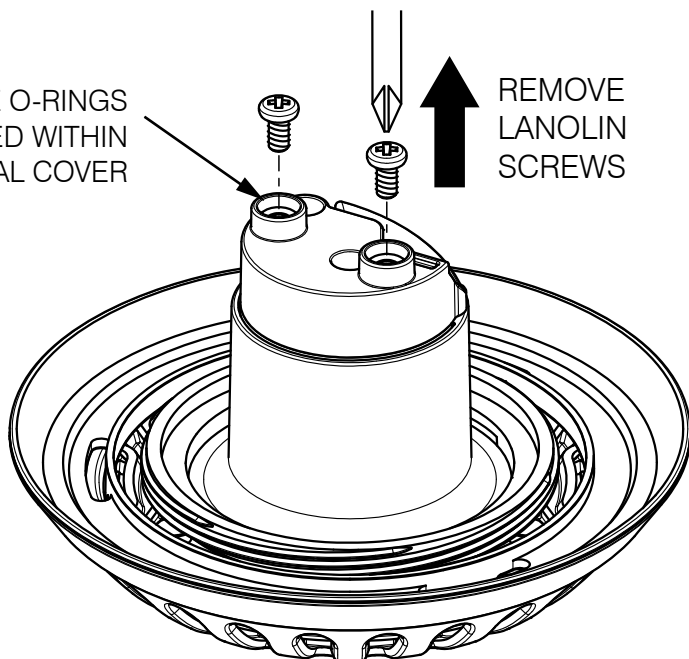

17

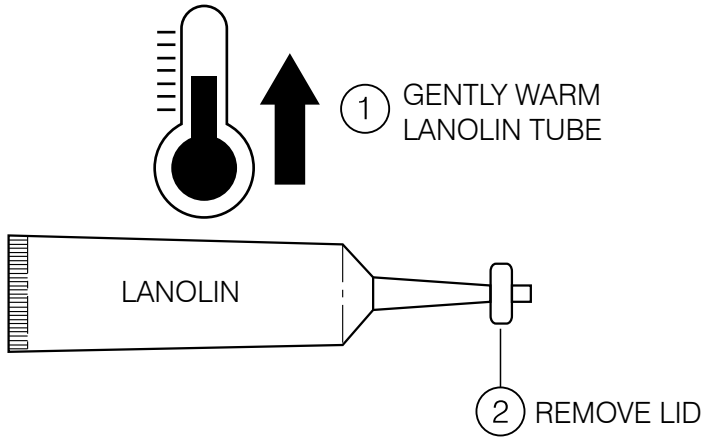

18

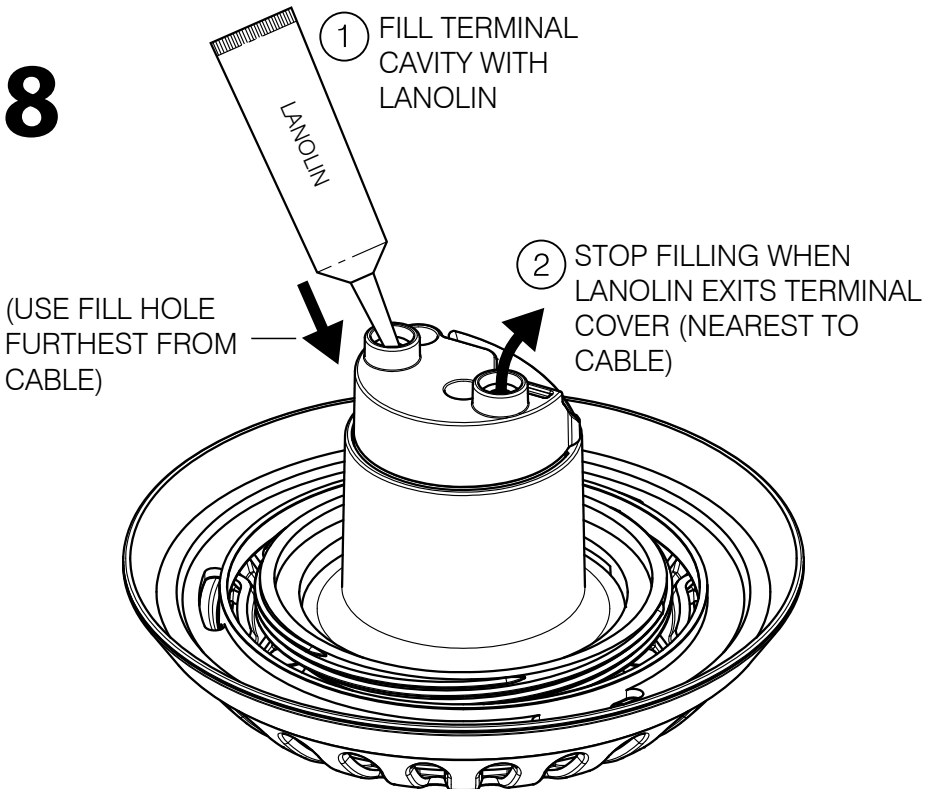

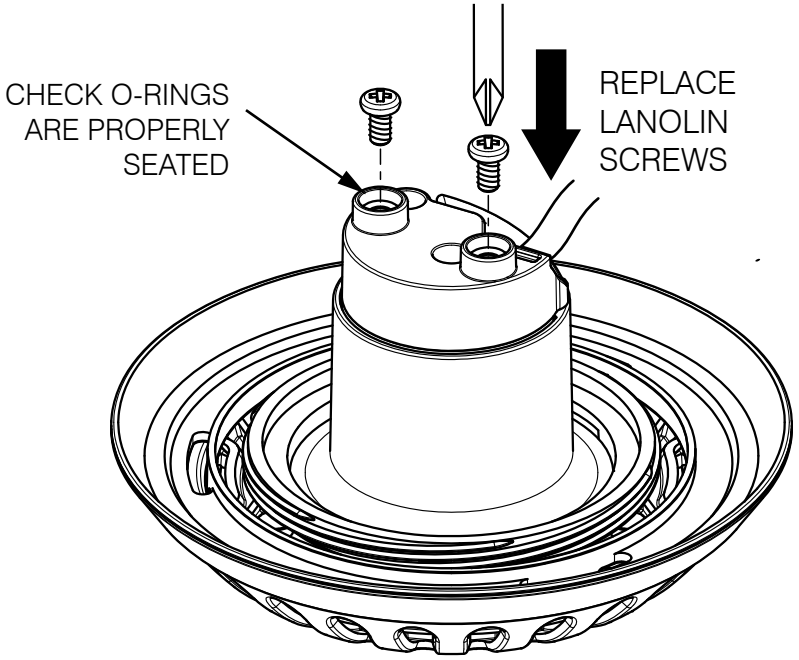

INSTALL EMRX TO NICHE

1

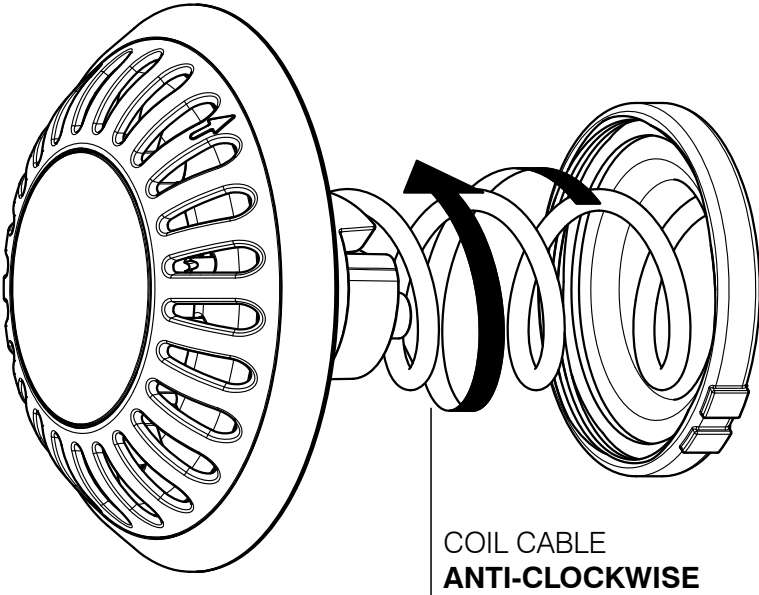

2

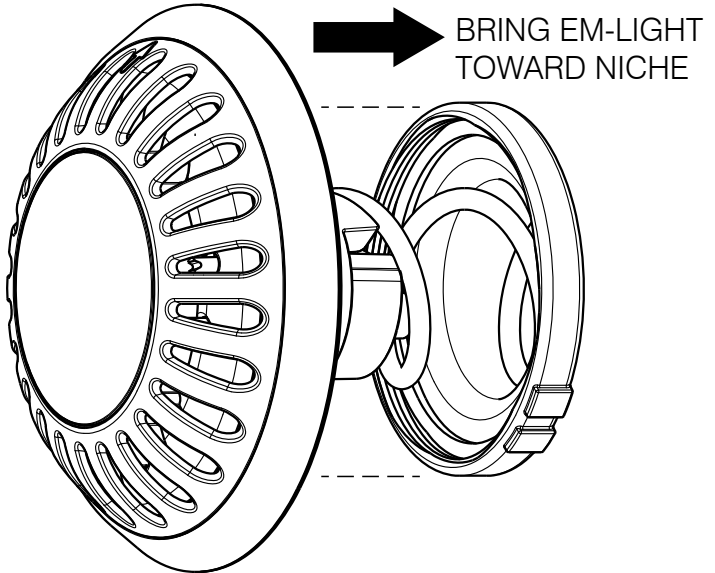

3

FIRMLY FASTEN
EM-LIGHT TO NICHE
(HAND TIGHT ONLY)

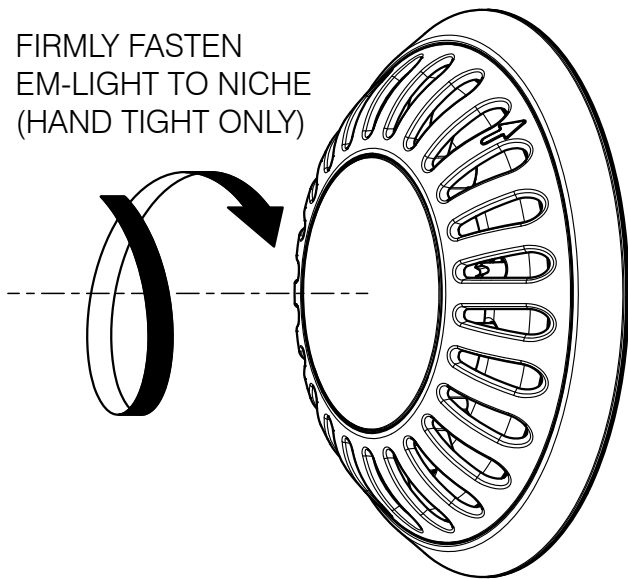
4 **(MULTI-LIGHT INSTALLATIONS ONLY)**

AIM FOR COMMON LOCATION OF RED
PUSH-BUTTON FOR CONSISTENT LED
COLOUR APPEARANCE

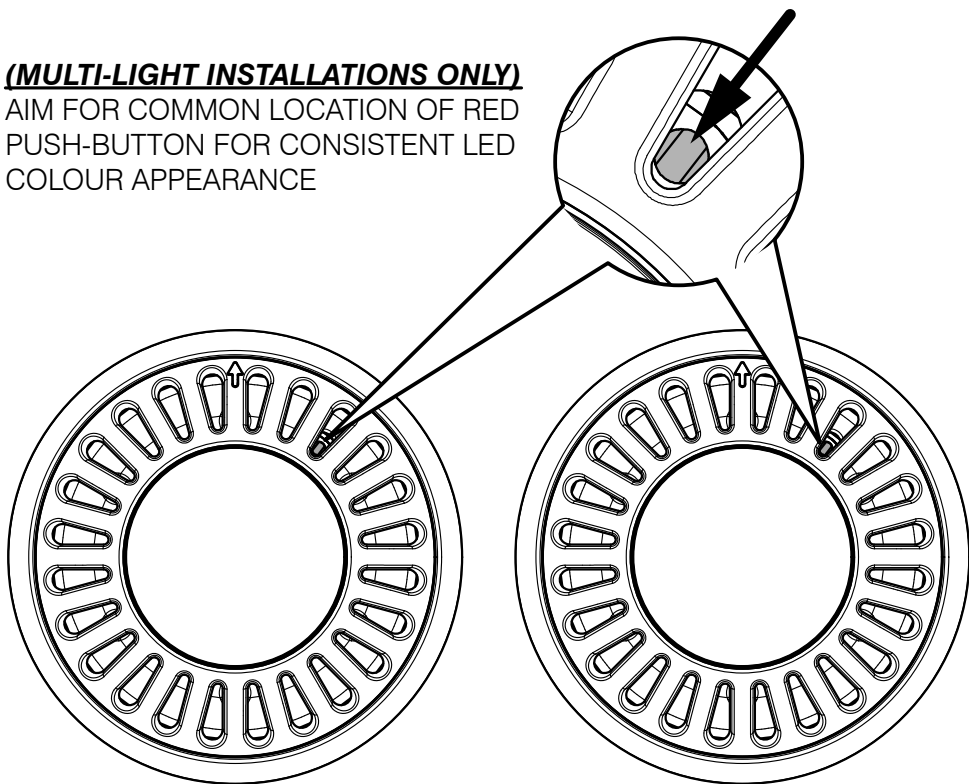

5

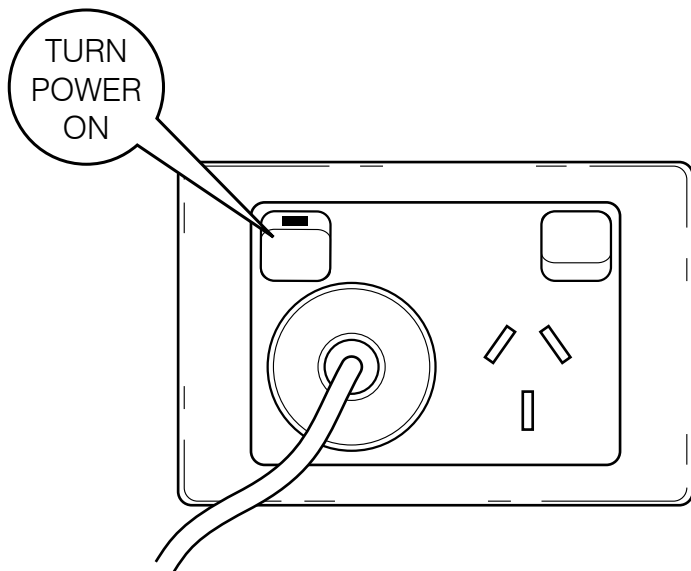

6

CHECK FOR CORRECT OPERATION

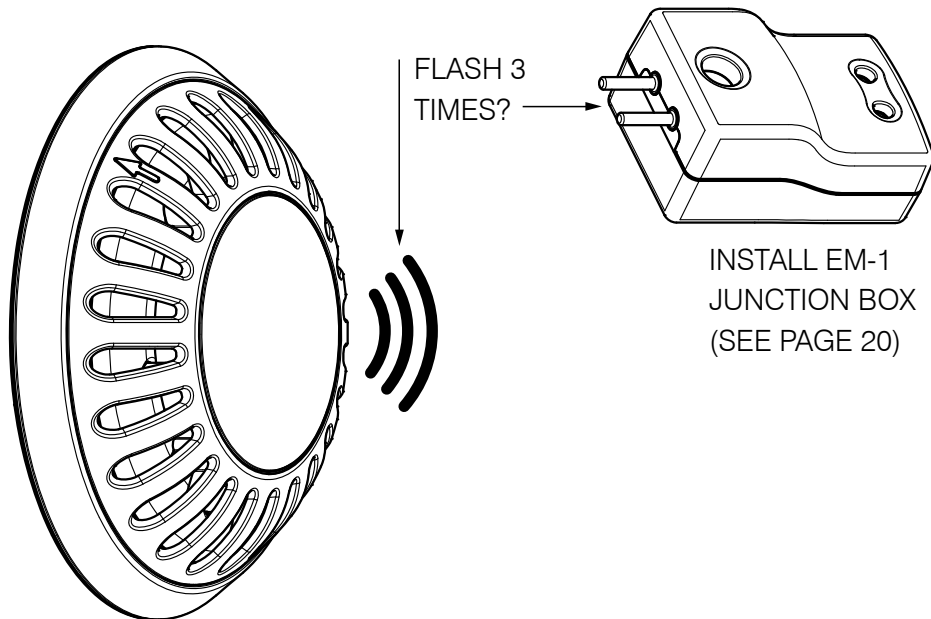

EM-1 INSTALLATION (DIRECT)

DIRECT CONNECTION OF EM-1 TO TRANSFORMER

THE FOLLOWING WALL MOUNTING ORIENTATIONS ARE RECOMMENDED TO MINIMISE WATER INGRESS:

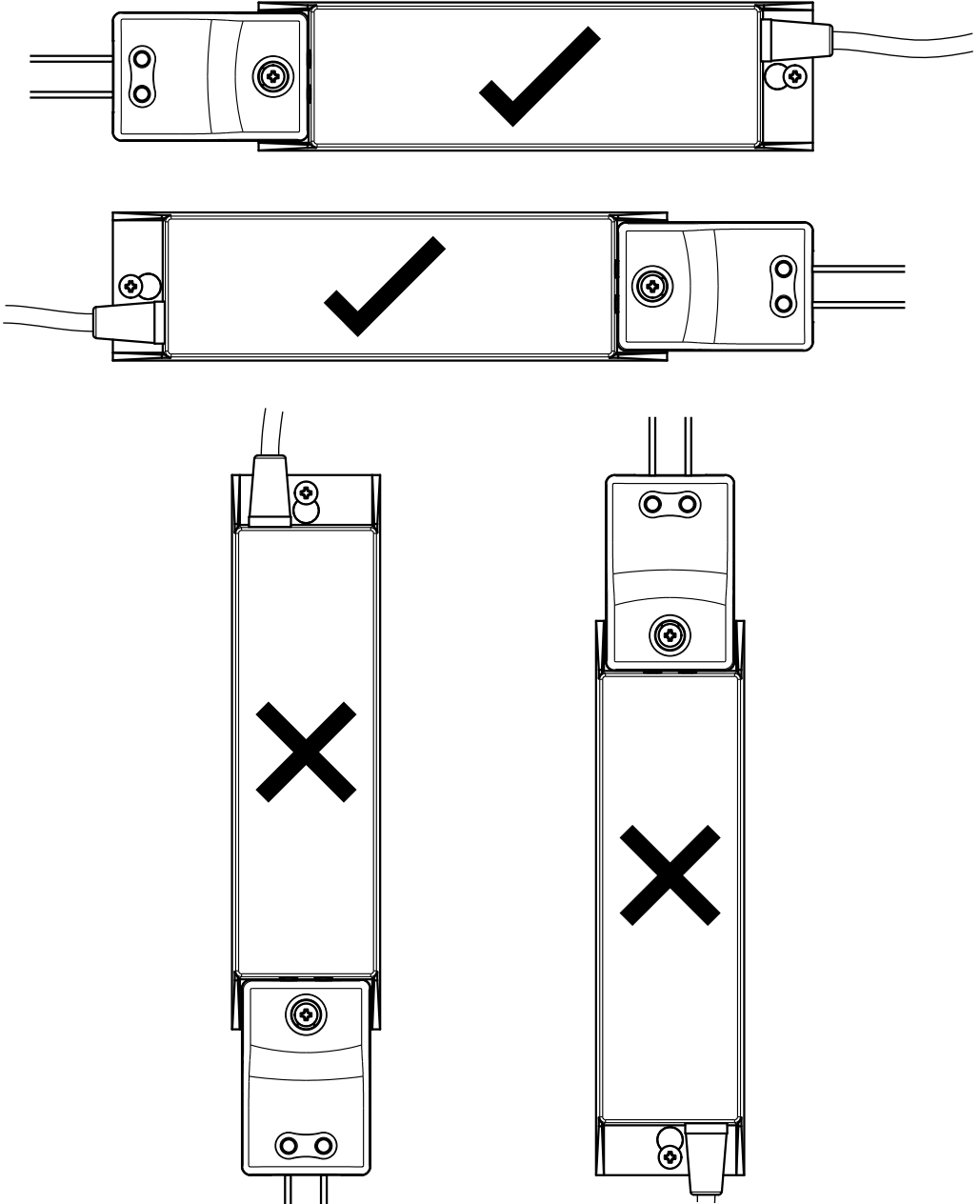

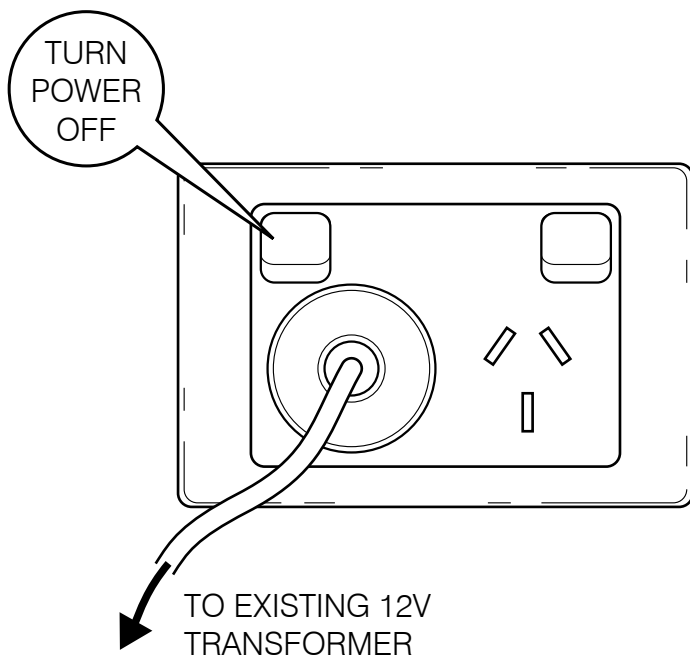
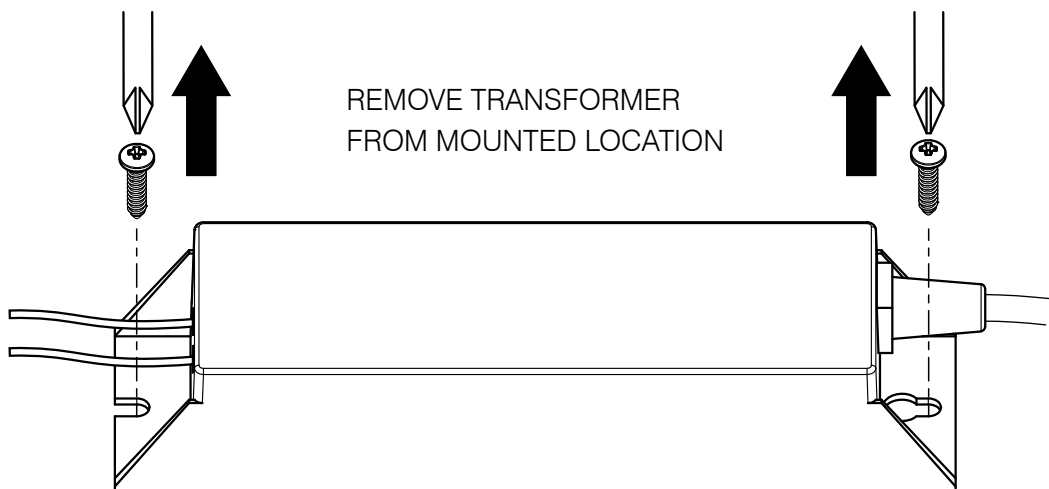
1**2**

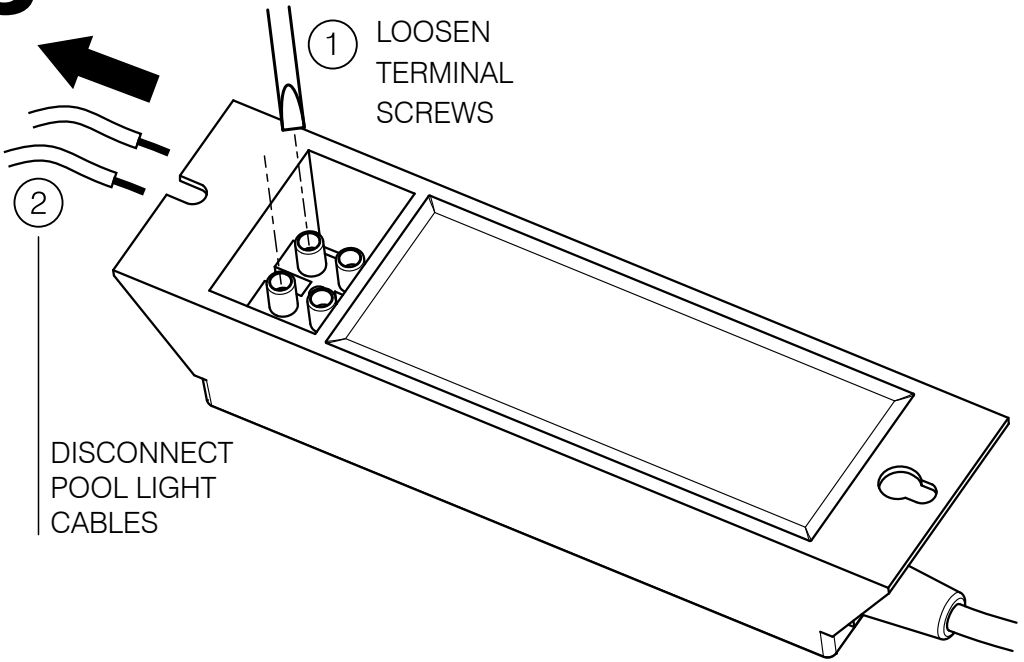
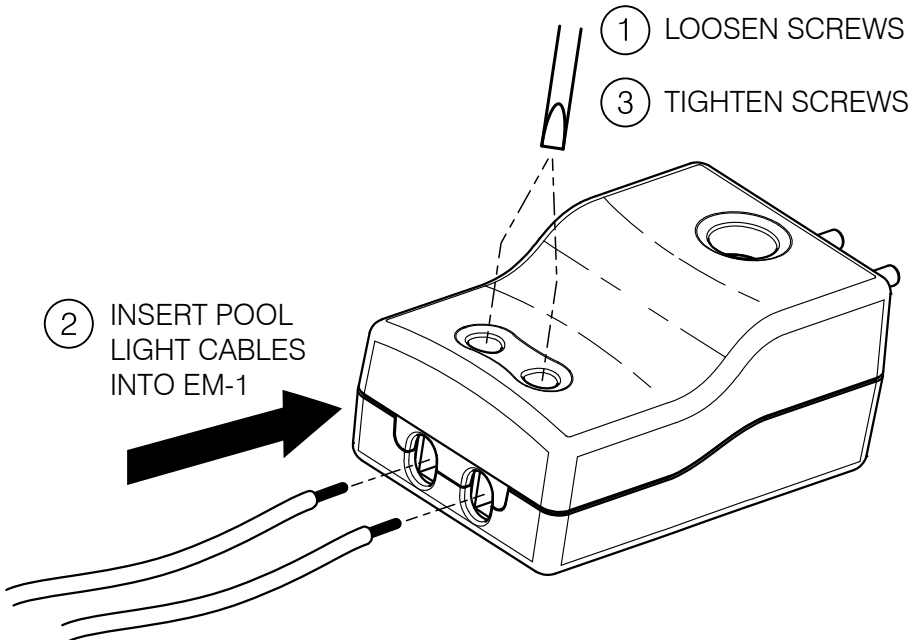
3**4**

5

① LOOSEN SCREWS

③ TIGHTEN SCREWS

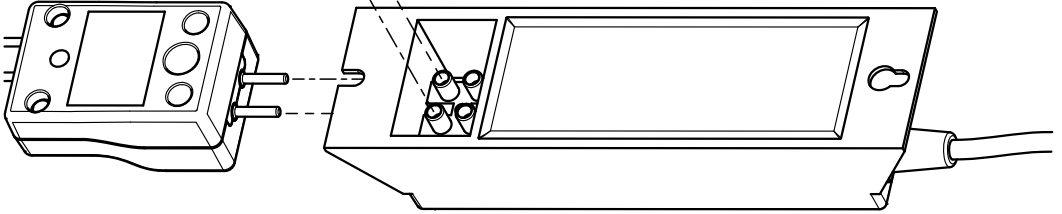

② ASSEMBLE EM-1 TO TRANSFORMER

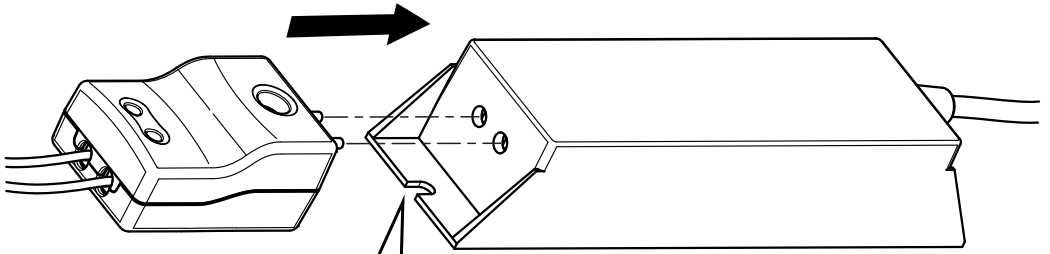

WON'T INSTALL PROPERLY?
SEE **PAGE 24**

6

RE-ATTACH TRANSFORMER
TO WALL MOUNTING

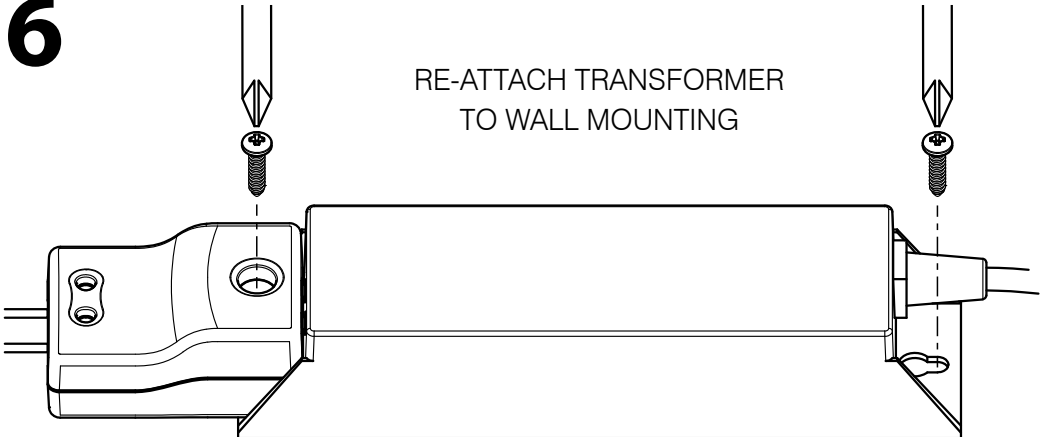

EM-1 INSTALLATION (REMOTE)

REMOTE CONNECTION OF EM-1 TO TRANSFORMER

IF YOU ENCOUNTER DIFFICULTIES INSERTING EM-1 DIRECTLY INTO EXISTING TRANSFORMER, FOLLOW THESE ALTERNATE INSTALLATION INSTRUCTIONS:

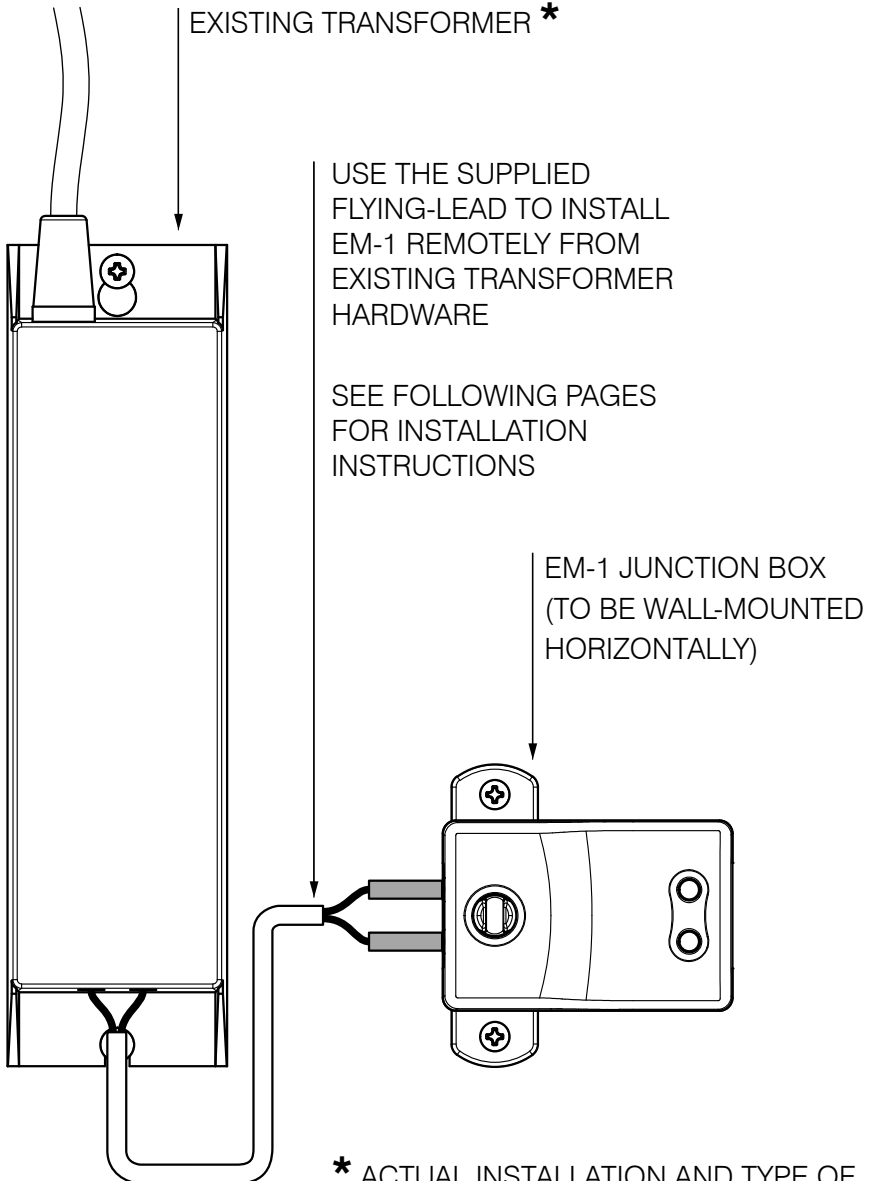

* ACTUAL INSTALLATION AND TYPE OF EXISTING TRANSFORMER MAY VARY

1

ASSEMBLE FLYING LEAD
TO EM-1 TERMINAL PINS

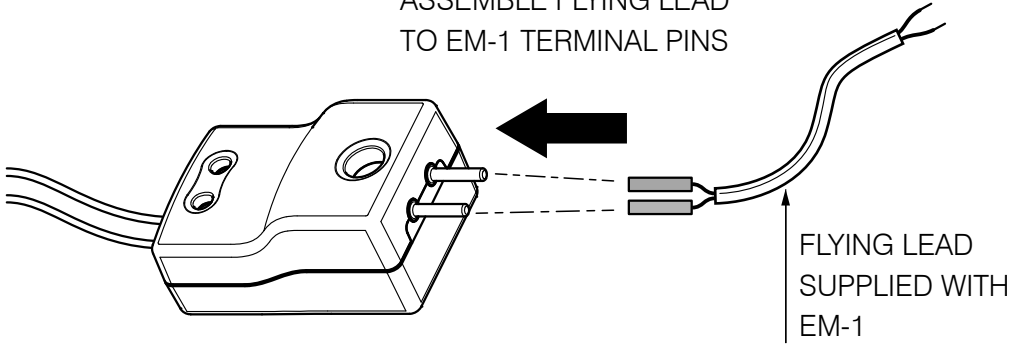
**2**

INSERT WIRES
INTO TRANSFORMER ①

② FASTEN FLYING-
LEAD WIRES INTO
TRANSFORMER'S
TERMINAL BLOCK

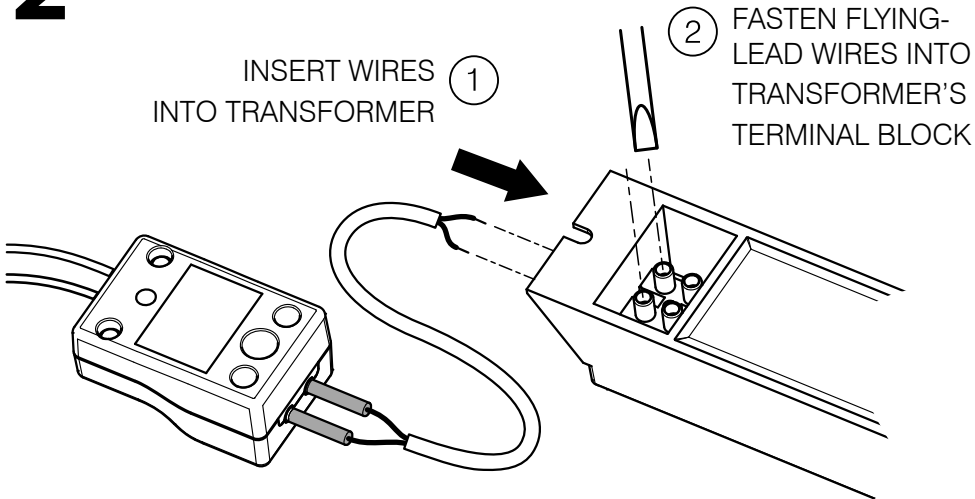

3

FASTEN SUPPLIED
MOUNTING BRACKET
TO WALL

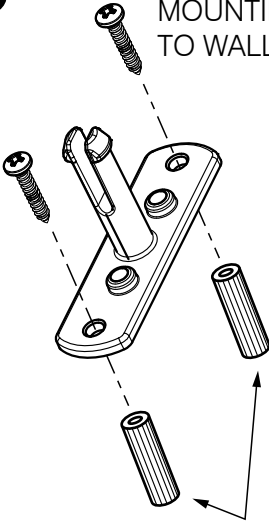

USE SUPPLIED WALL-PLUGS IN
MASONRY INSTALLATIONS

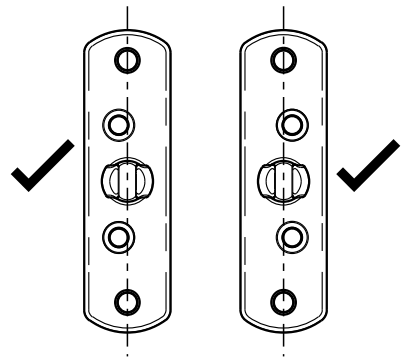

VERTICAL MOUNT ONLY

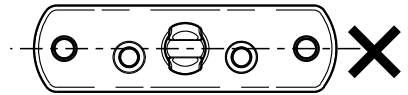
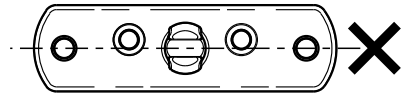

4

ASSEMBLE EM-1 TO
MOUNTING BRACKET

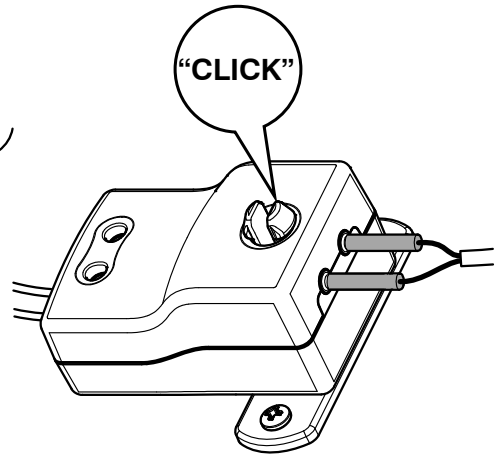
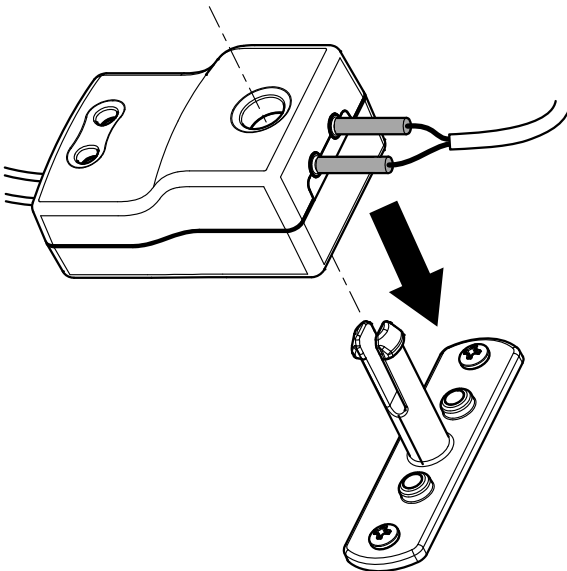

RE-ATTACH
TRANSFORMER
TO WALL MOUNTING

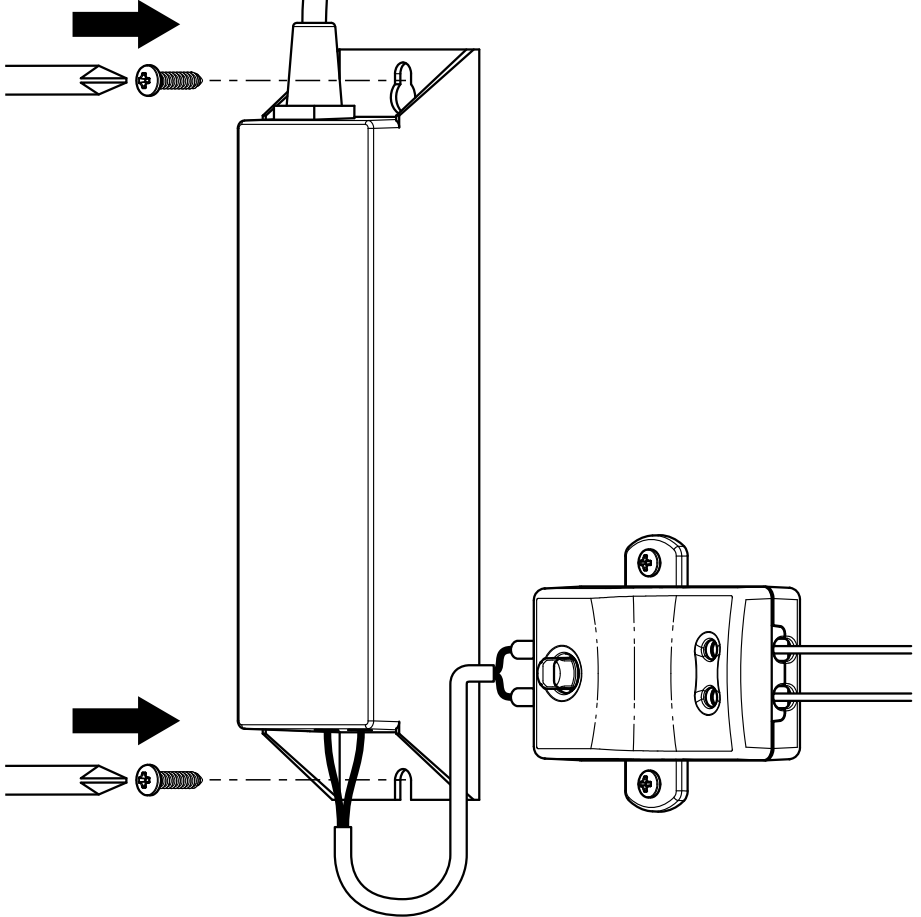

SUPPLIED CABLE CAN BE
SHORTENED AT THIS END
TO SUIT INDIVIDUAL
INSTALLATION SCENARIOS

TROUBLESHOOTING

MODEL: EMRX

ISSUE	REASON	ACTION
Light flashing Blue continuously	System is in "Reset" mode	Refer to multi-colour operating instructions
Light flashes 2 times	Light over heating	Check light is fully submerged Check vents are not obscured
Light flashes 3 times	Cable too short	Extend cable to original length or Connect EM-1 Junction Box to cable
Light not operating (1)	Faulty connection at transformer or light	Confirm connection at light & transformer as per instructions; Ensure no frayed or loose wires
Light not operating (2)	Mains power not connected or switched "ON"	Check transformer is plugged in to GPO and switched "ON"
Light not operating (3)	Damaged cable	Replace cable
Light not operating (4)	Faulty transformer	Check transformer output with multimeter under load (ie. 20W 12V)
Light not operating (5)	Damage caused by high voltage and/or incorrect power supply.	Return product to Spa Electrics for repair
Light colours not synchronised	Power interruptions or lights have been used individually	Reset lights - refer to EM-series operating instructions

If these issues cannot be resolved with the above recommended actions, please contact your distributor or Spa Electrics.

© COPYRIGHT 2011 SPA ELECTRICS PTY. LTD.
ALL RIGHTS RESERVED

20110421